

EHD-AZ5030UV, 2/3" UV Lens

No.	Name	Specification	No.	Name	Specification
1	Model	EHD-AZ5030UV	10	F.o.V 2/3"	D12.55, H10.06, V7.55
2	Format	2/3"	11	Working Distance	0.3m – inf.
3	Resolution	100lp/mm (2MP)	12	Wavelength	200 – 1000nm
4	Mount	C	13	Filter Thread	M34 x 0.5
5	F No.	F3.0 – 32	14	Dimension	D=37.6mm x l=49.51mm
6	Back Focus	26.55mm	15	Weight	110g
7	Iris Type	Manual			
8	EFL	50mm			
9	Distortion	< 0.1%			

Dimensions

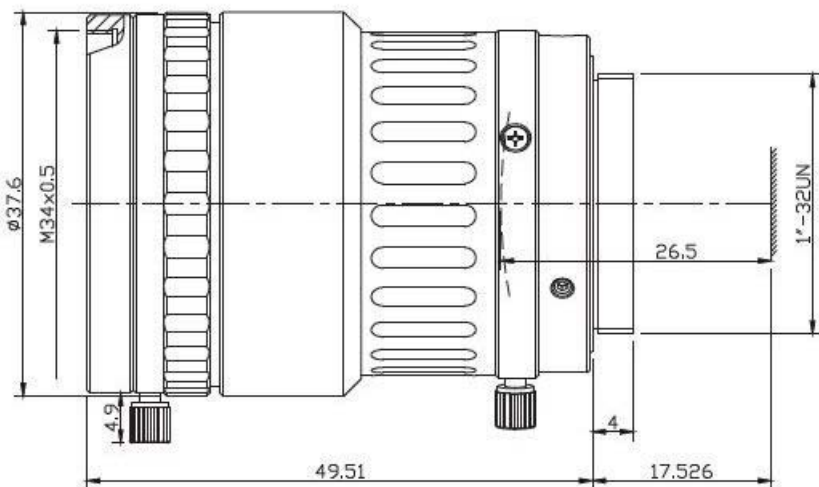

Optical Design Report

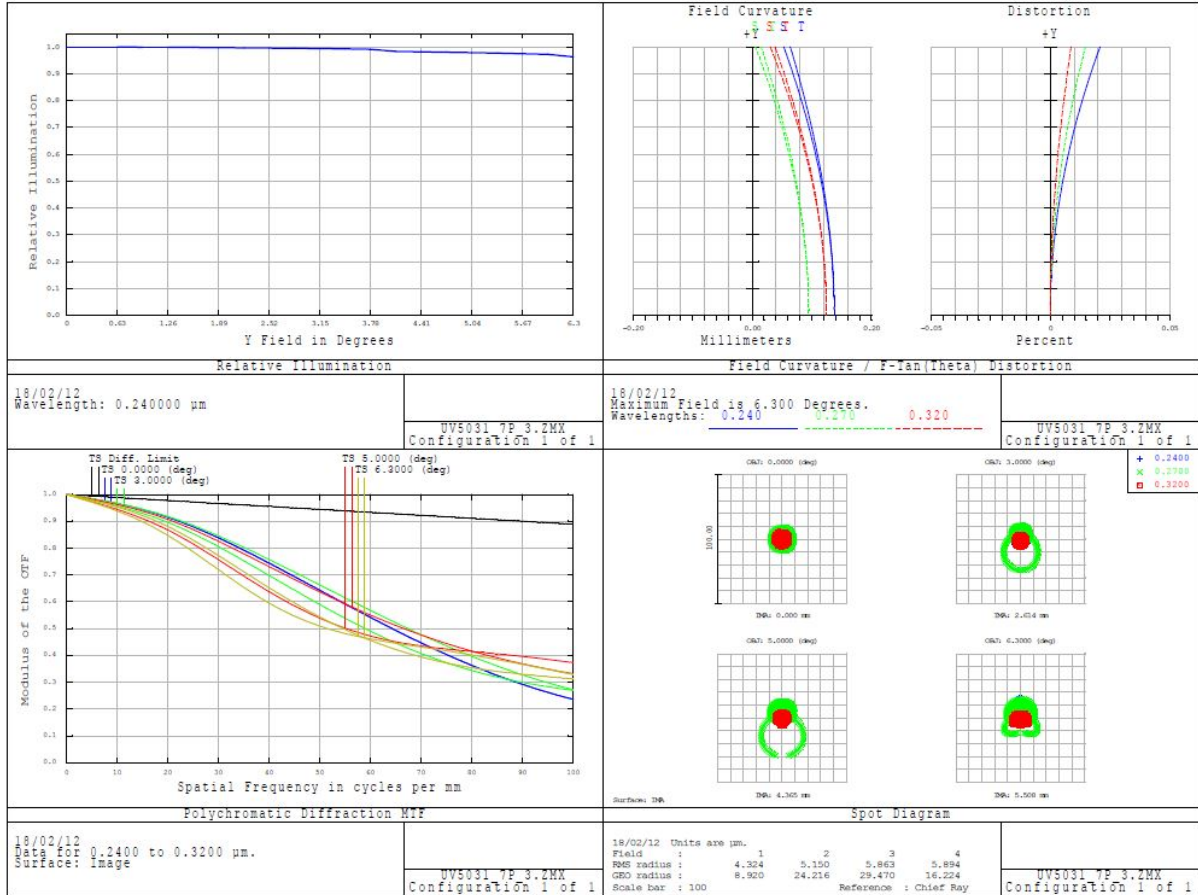

Produkt Image

